

B. Recommended Interface Circuit

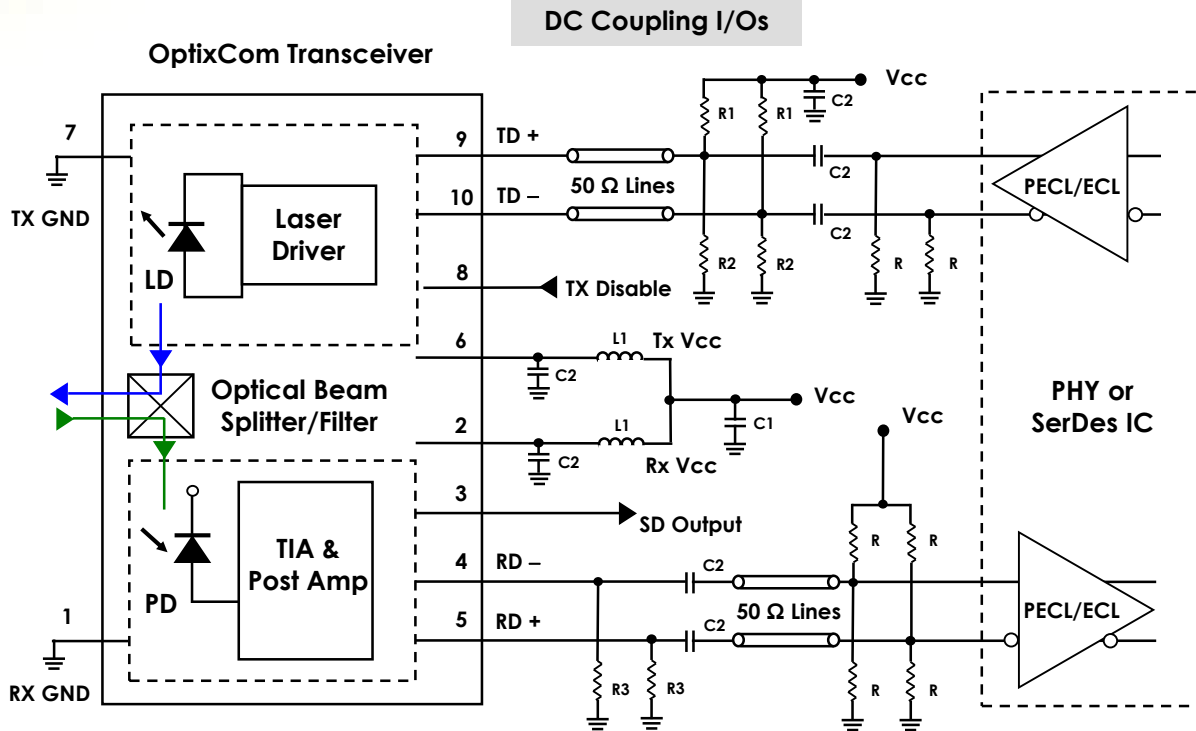

C1: 4.7 μ F, C2: 100 nF, L1: 1 μ H, R1: 82 Ω , R2: 130 Ω , R3: 180 Ω , R: depends on SerDes IC

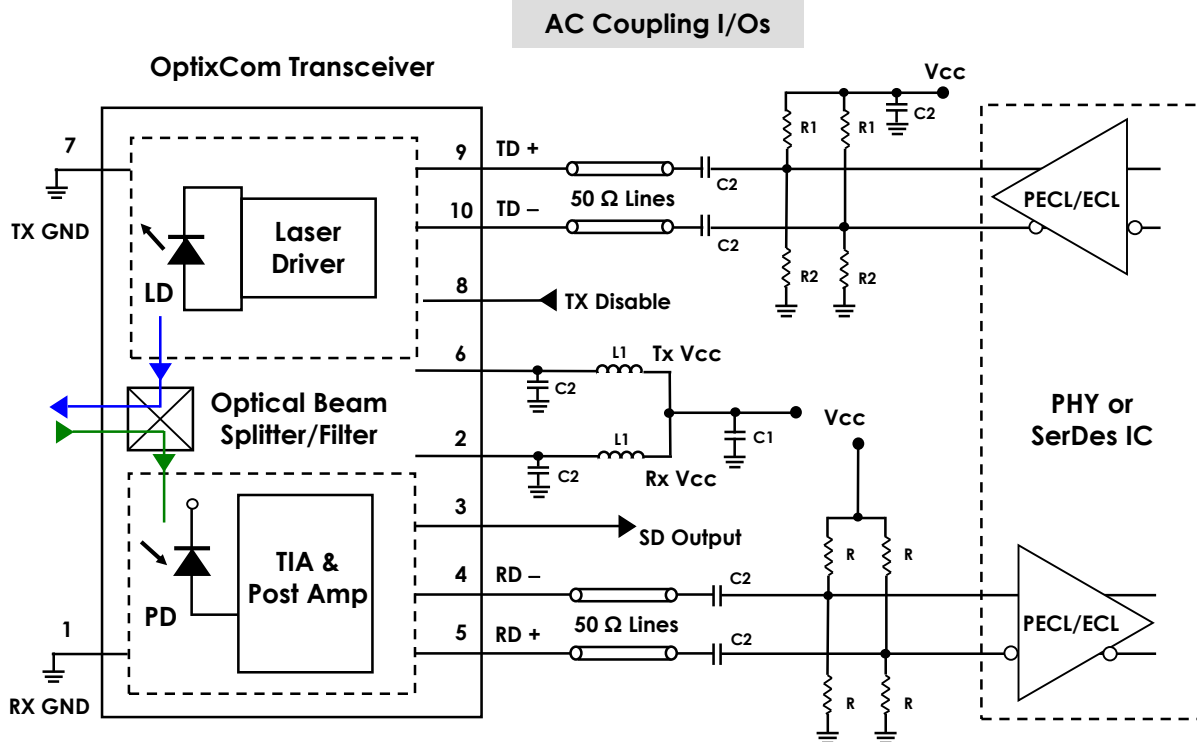

D. Package Outline

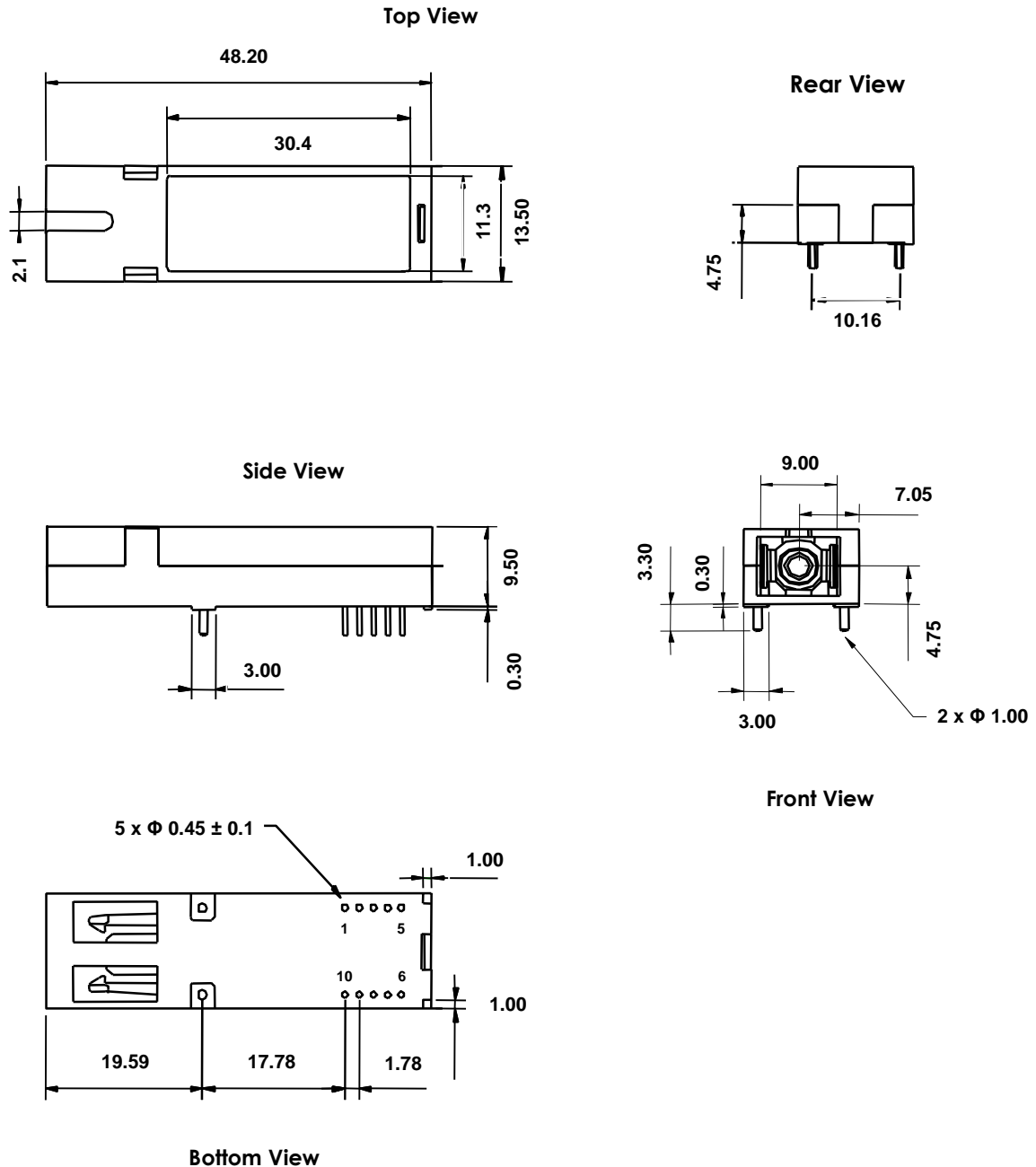

Unit: mm, typical tolerance for these dimensions is \pm 0.1 mm